

Efficiently testing car antennas for broadcast signals

Two R&S®ETL TV analyzers measure the receive level of a car antenna against that of a reference antenna. The measured data is exported by the R&S®BCDRIVE broadcast drive test software for display in Google Earth.

Your task

Today's cars have multiple antennas. More and more often, UHF antennas for digital TV are also included. The vehicle's design normally does not allow these antennas to be positioned vertically in the center of its roof, although this would provide optimal functionality. A compromise must be made between design and function.

Therefore, it is all the more important to test the receive level of these antennas in real-world operation. Up to now, drive tests had to be performed in areas with known receive conditions. The receive level was usually assessed indirectly, by subjectively evaluating the program quality. This approach is time-consuming, inaccurate and difficult to reproduce.

What's needed is a test method requiring only a minimum number of drive tests. If reception problems occur, it must be possible to determine whether they are caused by the antenna under test or by insufficient network coverage. In addition, the difference between the actual and the reference receive level must be displayed.

T&M solution

The receive level of the car antenna is measured against that of a reference antenna of known quality. The reference antenna is mounted such that it has optimal receive conditions. In most countries, vertically polarized broadcast signals are transmitted. The ideal antenna position for this is upright in the center of the car's roof. Two R&S®ETL TV analyzers are used for the measurement. One of them (the slave) measures the receive level of the antenna under test; the other (the master) measures that of the reference antenna.

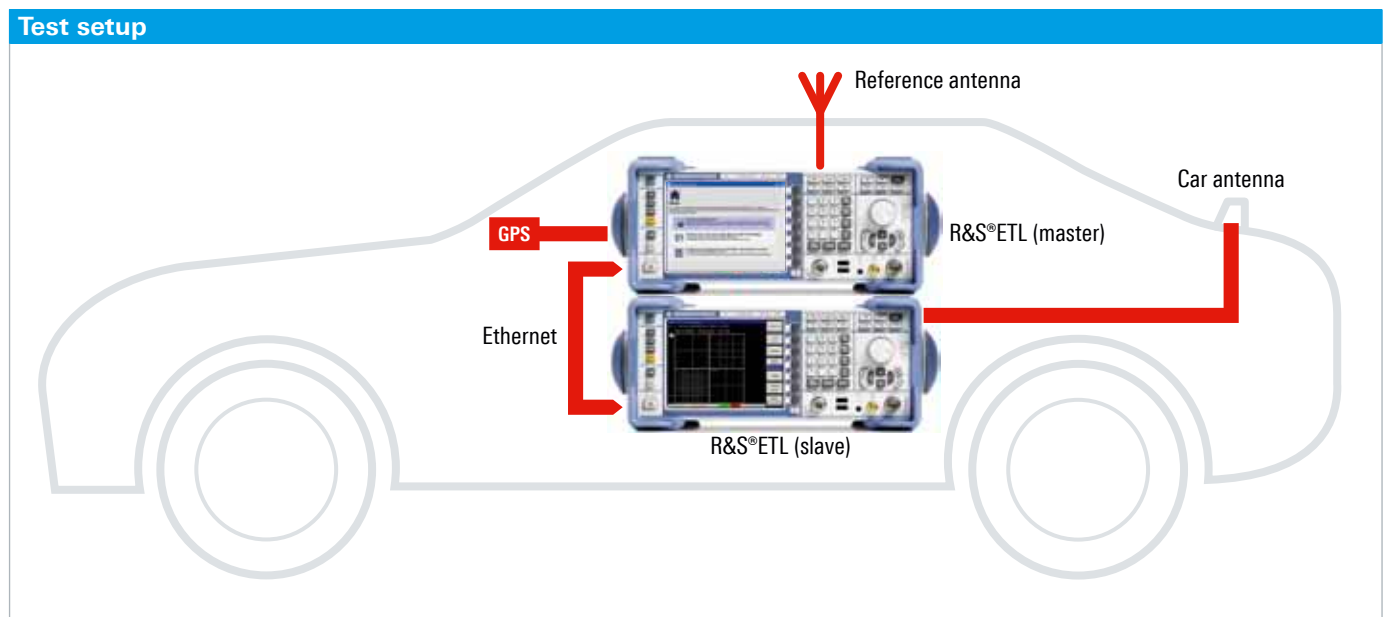

Depending on the conditions in the vehicle, power can be supplied by a battery inside the R&S®ETL, the vehicle's 12 V DC supply system or a 230 V AC voltage. In addition, the master analyzer is connected to an R&S®TSMX-PPS GPS receiver so that it can permanently record the vehicle's position.

The measurement is controlled by the R&S®BCDRIVE broadcast drive test software. It runs on the master R&S®ETL and synchronously controls both the master and the slave R&S®ETL, which is connected via Ethernet. It also records the vehicle position data from the GPS receiver and saves all measurement data, including time stamp, at intervals of one second to the internal hard disk or a USB stick; a computer is not required. 100 Mbyte of free memory space is enough for many hours of measurement.

Result display

Following the drive test, the measurement data is exported from the R&S®BCDRIVE software and converted to KMZ format for display in Google Earth. Areas with poor reception are then easy to recognize.

Comparing the receive levels of the reference antenna and the car antenna shows the cause of reception problems:

- If the level of the car antenna is poor and that of the reference antenna is strong, the problem is caused by the car antenna
- If both antennas have poor reception, the receive field strength is insufficient and the car antenna is working correctly

The R&S®BCDRIVE software can also provide the measured data in CSV format, allowing it to be processed with MS Excel or other programs.

The R&S®ETL TV analyzer can be fitted with options for the following broadcast standards: DVB-T, DVB-T2, ISDB-T, T-DMB, DTMB, ATSC and ATSC-M/H, as well as DAB and VHF sound broadcasting. The Application can therefore be used in most countries throughout the world.

See also:

www.rohde-schwarz.com/product/ETL

www.rohde-schwarz.com/product/BCDRIVE

Result display

The R&S®BCDRIVE software processes measurement results such that the receive characteristics of the car antenna and the reference antenna can be clearly compared in Google Earth. In the picture above, the test points are represented by circles. The receive levels of the reference antenna are visualized by the inner area of the circles in color in accordance with the legend, whereas the outer edges represent the receive levels of the car antenna. In this example, the reference antenna provides a receive level approx. 15 dB higher than that of the car antenna.

Rohde & Schwarz GmbH & Co. KG

Europe, Africa, Middle East +49 89 4129 123 45

customersupport@rohde-schwarz.com

North America 1 888 TEST RSA (1 888 837 8772)

customer.support@rsa.rohde-schwarz.com

Latin America +1 410 910 7988 | customersupport.la@rohde-schwarz.com

Asia/Pacific +65 65 13 04 88 | customersupport.asia@rohde-schwarz.com

China +86 800 810 8228/+86 400 650 5896

customersupport.china@rohde-schwarz.com

www.rohde-schwarz.com

R&S® is a registered trademark of Rohde & Schwarz GmbH & Co. KG

Trade names are trademarks of the owners | Printed in Germany (sv)

R&S®ETL, R&S®BCDRIVE | PD 5214.5290.92 | Version 01.00 September 2011

Data without tolerance limits is not binding | Subject to change

© 2011 Rohde & Schwarz GmbH & Co. KG | 81671 München, Germany



5214529092